

Opening the lid and taking out battery:

Step 1. Insert a small flat screw driver or preferably 1/4" wood chisel into the gap as illustrated; rotate the handle to pry open the lid. (latches are located at locations 1~6, open them in same order)

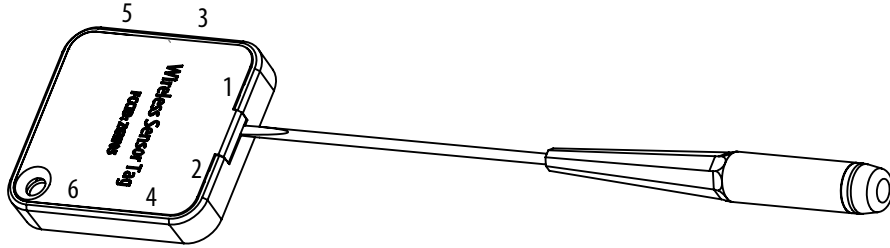

Step 2. The circuit board is fitted (without any glue) front-side down in the casing. Use the screwdriver/chisel to remove the board.

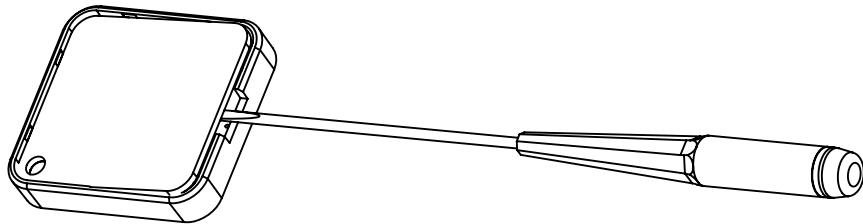

Step 3. Battery (CR2032) is located on the front side of the circuit board, slide out the battery from the battery holder and insert new one.

Closing the lid:

Step 1. Push the circuit board front-side down into case aligning the hole location

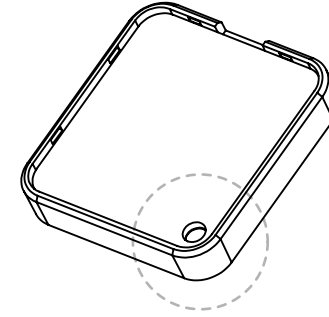

Step 2. Insert the two hooks (1) at the bottom edge of the lid into matching grooves in the case



Step 3. Close the lid by pushing down where the hooks (2~4) are, one at a time

